

Item No.

### Reliable Even-Cooking Griddle Provides Outstanding Performance for Breakfast, Lunch or Dinner Menu Items

This series of griddles features exclusive plate temperature sensors which respond to temperature fluctuations quickly. **Individual thermostatically controlled burners every 12 inches** maintain consistent temperatures under heavy load conditions. Precise thermostats allow separate heat zones for different products. Cook foods to golden perfection with Anets GoldenGrill™ Gas Griddle.

#### STANDARD FEATURES

- High nickel content 3/4" precision ground hot rolled steel plate
- One burner per foot: 30,000 BTUH per burner
- Stainless steel front, sides, grease trough and splashguards
- Snap action thermostats
- Spark ignitor for lighting pilots
- 100% gas safety valve shut-off
- Double wall construction keeps the operator and kitchen cool
- No electrical connection required
- Front grease trough allows for more usable griddle surface
- Extra large grease chute opening equipped with built in spatula scraper
- Large capacity 5.7 quart grease drawer easily accessible under cabinet and equipped with anti-splash guards. (72" model is equipped with 2 drawers)



A24X48G shown on legs



A24X48G shown on optional stainless steel stand with undershelf

**A N E T S**  
**GoldenGRILL™**





## SPECIFICATIONS

- Model AG Models (See chart below)
- Certification ETL, CETL, NSF
- BTUH input 30,000 per burner (foot),  
NG 3.5" WC, LP 10" WC,  
Pressure regulator included
- Gas Pressure 3/4" NPT
- Gas Connection None
- Electrical High nickel content 3/4" precision  
ground hot rolled steel plate
- Plate Aluminized steel
- Burners Gas operated, snap action
- Thermostats 200-550F (93-288C)
- Temperature Range 100% gas shut-off valve
- Safety Pilots Piezo electric
- Spark ignitor Front, sides, trough and splashguard,  
stainless steel
- Cabinet Back, aluminized steel

## STANDARD ACCESSORIES

- Safety pilots
- Stainless steel sides
- Spark ignitor
- Pressure regulator
- 4" Adjustable chrome plated legs

## DIMENSIONS

### 24" MODELS

Overall	A24X24G	A24X36G	A24X48G	A24X60G	A24X72G
■ (W) Width	24.25"	36.25"	48.25"	60.25"	72.25"
■ Height	17.25"	17.25"	17.25"	17.25"	17.25"
■ Depth	29.75"	29.75"	29.75"	29.75"	29.75"
<b>Plate</b>					
■ Width	24"	36"	48"	60"	72"
■ (D) Depth	24"	24"	24"	24"	24"
NG BTUH	60,000	90,000	120,000	150,000	180,000
LP BTUH	60,000	90,000	120,000	150,000	180,000

Specifications subject to change without notice.  
SS# 210 Revised 10/06  
Printed in the U.S.A.

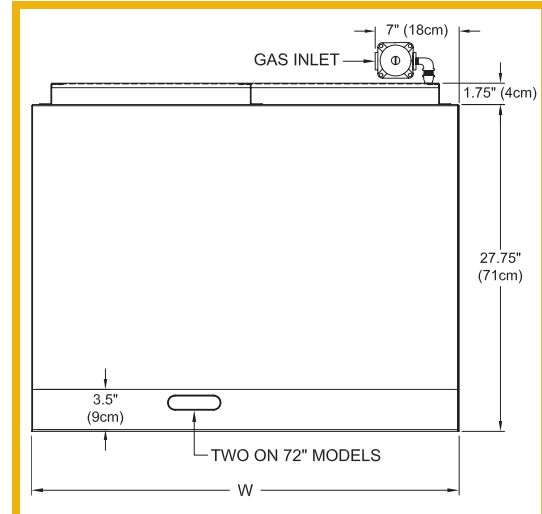

Top View

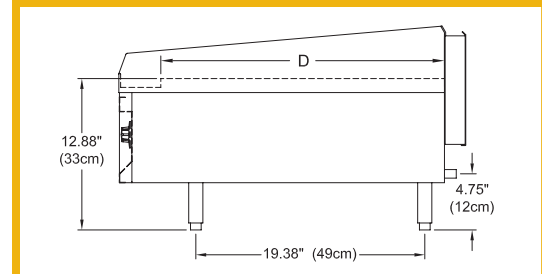

Side View

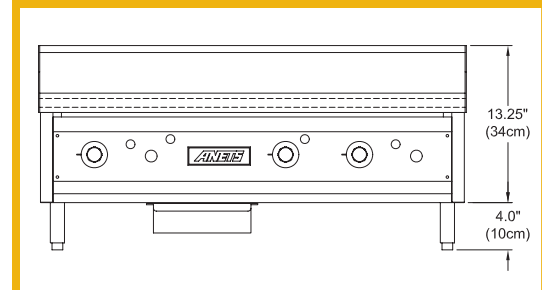

Front View

Current construction on 24", 36" and 48" wide griddles are 1/2" taller than indicated in drawing. Current construction subject to change. Contact factory for current dimensions if required.