

Item No.

## Keep your foods crisp, hot and handy with the Anets Crispy Food Warmer

The Anets Crispy Food Warmer holds "fry ahead" production. Efficient infrared heat keeps foods fresh and hot. An easily removable bulb guard protects the bulbs from damage. To accommodate a variety of products, the stainless steel hood is adjustable to three different heights. The unit fits on an Anets Drain Shelf creating a dump station without using any floor space. The Crispy Food Warmer is also available as an option on a Filtronic™ II filter system dump station.

### STANDARD FEATURES

- Two infrared bulbs in choice of white or red.
- Teflon-coated bulbs are shatterproof.
- Stainless steel hood is adjustable to three different heights.
- A large easy to clean stainless steel pan with rack is provided. (12½" X 20½" X 2½").
- Equipped with an ON/OFF switch.
- Six foot cord and plug provided.



A N E T S  
**GoldenFRY™**



# Anets Crispy Food Warmer

Model CFW



## SPECIFICATIONS

■ Model CFW  
FW

- Certification
- Electrical Requirements
- Hood Finish
- Legs/Stand

Crispy Food Warmer  
Filtronic II filter system equipped  
with CFW

UL, NSF

115V, 4.3 Amps, 500 Watts

Stainless steel

Chrome plated

## STANDARD ACCESSORIES

- 6 foot grounded cord and plug
- (2) 250 Watt White shatterproof bulbs

## OPTIONS AND ACCESSORIES

- (2) 250 Watt Red shatterproof bulbs

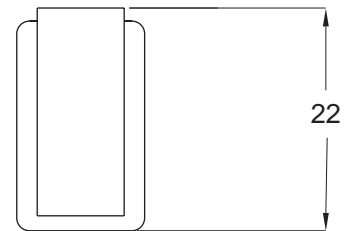

Top View

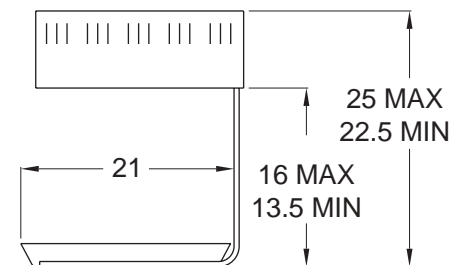

Side View

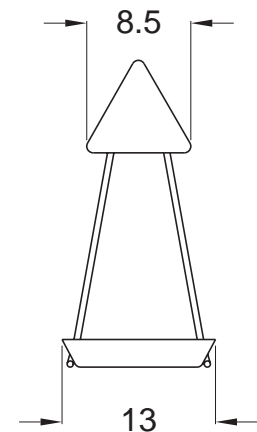

Front View

Specifications subject to change without notice.  
SS# 340 Revised 3/04  
Printed in the U.S.A.



Anetsberger Brothers, Inc. ■ Foodservice Equipment That Turns Food Into Gold  
180 North Anets Drive ■ Northbrook, Illinois 60062  
1-800-837-2638 ■ Fax 847-272-1943 ■ [www.anetsberger.com](http://www.anetsberger.com)