

Item No.

## New Anets Fryer Meets Your Requirements With A Full Range Of Options Available to Streamline Your Frying Operations

This standard Anets fryer is now available with a full range of options making it very versatile yet affordable. Utilizing the exclusive Anets heating system, the fryer provides outstanding production capacity and the recovery necessary to keep up with a demanding kitchen. The patented 4 sided heating system uses crossfire burners with special flame spreaders to maximize heat input. The open vat design is easy to clean and features a large cold zone for longer shortening life. Depend on your Anets fryer for years of service backed by a lifetime warranty on the frypot.

### STANDARD FEATURES

- Stainless steel frypot has a **lifetime warranty**
- Stainless steel front panel, trim and door
- Open vat design with sloped sides forces food particles to rapidly fall into the easily accessible cold zone
- Unique crossfire burners provide a 4 sided heating system
- Fully insulated cabinet keeps the kitchen cool
- Dual (35 to 50 lb.) shortening levels for varying cooking capacities
- Recessed Lexan faced control panel protects controls from damage
- Stainless steel basket hanger lifts off for easy cleaning and access to the backslash



MX-14EX shown on optional casters

**A N E T S**  
**GoldenFry™**



# Anets GoldenFry™ 14" High Production Gas Fryer

# Model MX-14EX



## SPECIFICATIONS

- Model: MX-14EX, 14" Gas Fryer
- Certification: UL, CUL, NSF
- BTUH: 111,000
- Gas Pressure: NG 3.5" WC, LP 10" WC
- Gas Connection: 3/4" NPT
- Electrical Requirements: 120V, 60Hz, 1Ph, 2 Amps
- Thermostat: Electric snap action type
- Temperature Range: 200° to 375°F, (93°-191°C)
- Burners: Atmospheric pre-mix
- Hi-limit: Safety control turns off main gas supply at 440°F (227°C)
- Safety Pilot: 100% gas shut off valve
- Spark Ignitor: Piezo electric
- Frypot: Stainless steel
- Cabinet: Front panel, door, trim and backsplash are Stainless Steel. Sides are painted
- Shortening Capacity: 35 lbs - 50 lbs
- Cooking Capacity: 70 lbs of fries per hour
- Frying Area: 14" x 14.5" (36cm x 37cm)

## STANDARD ACCESSORIES

- 2 Twin nickel plated baskets
- Rack type basket support
- Clean out rod
- 6" Adjustable legs
- Drain pipe extension

## OPTIONS AND ACCESSORIES

- Automatic twin basket lift (Model MX - 14EXAA)
- Stainless steel sides
- Filter systems, built-in Filtronic or Filter Mate under fryer filter
- Fri-Tronic™ multi-product computers with shortening melter, boil out mode and digital timers
- Shortening melter
- Can bank units at no additional charge
- Sediment tray
- Single or triple baskets
- Drain table
- Front drain tray
- Fryer cover
- Casters
- Electronic ignition
- Solid State thermostat
- Fryer cleaning brush

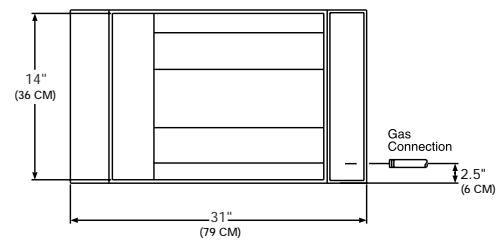

Top View

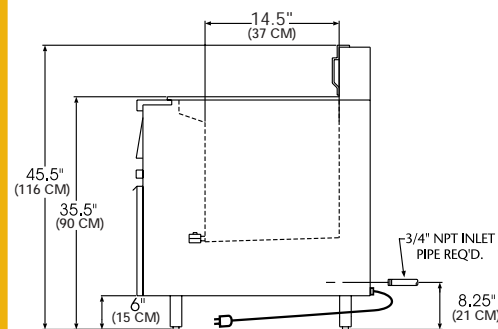

Side View

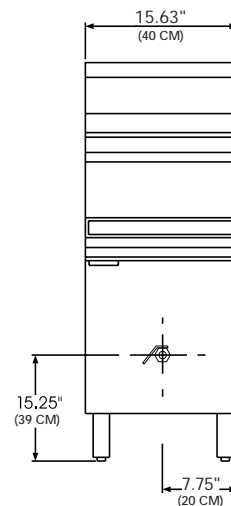

Front View

Specifications subject to change without notice.  
SS# 108 Revised 12/03  
Printed in the U.S.A.

