

Item No.

### Fry Large Batches Of Food With No Electrical Hook-Up Required

Equipped with a gas operated thermostat, this model meets all the requirements necessary to cook large batches of fish, chicken, appetizers, and french fries. The exclusive tube design provides fast recovery, minimizes cleanup time, and maximizes heat transfer. The elliptical shape of the tubes eliminates sedimentation on tubes, improves shortening life and minimizes the number of times you have to drain fryer. The stainless steel tubes accommodate 150,000 BTUH burners and feature computer designed radiants for the best performance and recovery.

#### STANDARD FEATURES

- Stainless steel frypot has a **lifetime warranty**
- No electrical hook-up required
- Stainless steel front panel, trim and door
- Tube type design assures maximum heat transfer in the 18" wide frypot
- Unique shape of tubes allows access to cold zone for easy cleaning
- Burner tubes are equipped with computer designed radiants for fast recovery and energy efficiency
- Dual shortening levels (70 to 100 lbs) for varying cooking capacities
- Recessed Lexan faced control panel protects controls from damage
- Stainless steel basket hanger lifts off for easy cleaning and access to the backplash



Model 18EG shown on legs

**A N E T S**  
**GoldenFry™**



# Anets GoldenFry™ 18" Fryer

## Model 18EG



### SPECIFICATIONS

- Model 18EG, 18" Gas Fryer with gas operated thermostat
- Certification UL, NSF
- BTUH 150,000
- Gas Pressure NG 3.5" WC, LP 10" WC
- Gas Connection 3/4" NPT
- Electrical Requirements None
- Thermostat Gas, snap action hydraulic control
- Temperature Range 200° to 375°F, (93°-191°C)
- Burners Atmospheric pre-mix
- Hi-limit Safety control turns off main gas supply at 440°F (227°C)
- Safety Pilot 100% gas shut off valve
- Spark Ignitor Piezo electric
- Frypot Stainless steel
- Tubes Stainless steel
- Cabinet Front panel, door, trim and backsplash are Stainless Steel. Sides are painted
- Shortening Capacity 70 lbs - 100 lbs
- Cooking Capacity 75 lbs. of chicken per hour  
110 lbs. of fries per hour
- Frying Area 18 x 18 (46 x 46cm)

### STANDARD ACCESSORIES

- 2 Nickel plated twin baskets
- Rack type basket support
- Clean out rod
- 6" Adjustable chrome plated legs
- Drain pipe extension
- Piezo ignitor

### OPTIONS AND ACCESSORIES

- Stainless steel sides
- Filter systems, built-in Filtronic or Filter Mate under fryer filter (under 2 fryers)
- Multiple units can be banked at no additional charge
- Single or triple baskets
- Drain table
- Fryer cover
- Front drain tray
- Casters

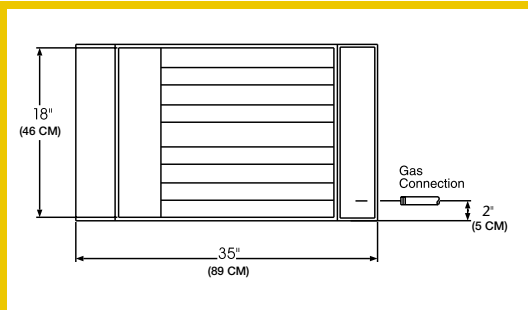

Top View

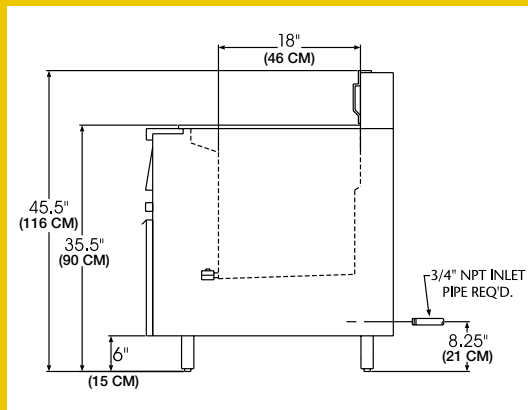

Side View

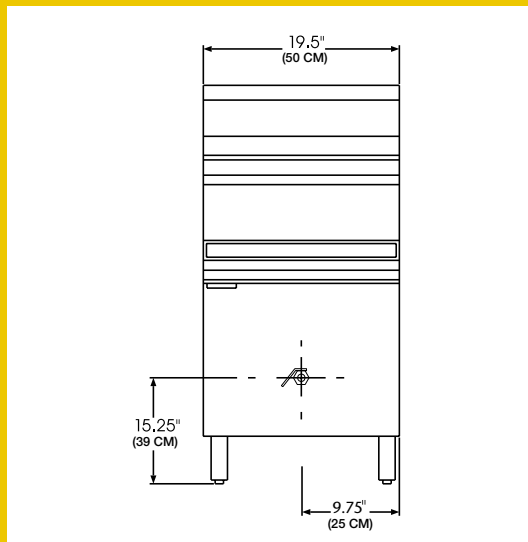

Front View

Specifications subject to change without notice.  
SS#121 Revised 8/02  
Printed in the U.S.A.



Anetsberger Brothers, Inc. ■ Foodservice Equipment That Turns Food Into Gold  
180 North Anets Drive ■ Northbrook, Illinois 60062  
1-800-837-2638 ■ Fax 847-272-1943 ■ www.anetsberger.com