

Item No.

Increase Output And Maintain Product Consistency With The Anets 18" GoldenFry™ Fryer With Automatic Basket Lifts

This 18" gas fryer is equipped with heavy duty lifts to remove the product at precisely the right cooking time. The exclusive tube design provides fast recovery, minimizes clean-up time and maximizes heat transfer. The elliptical shape of the tubes eliminates sedimentation on tubes, improves shortening life and minimizes the number of times you have to drain fryer. The stainless steel tubes accommodate 150,000 BTUH burners and feature computer designed radiants for the best performance and recovery.

STANDARD FEATURES

- Stainless steel frypot has a lifetime warranty
- Two heavy duty automatic basket lifts assure product consistency
- Chrome plated basket lifts simply lift off for easy cleaning
- Tube type design assures maximum heat transfer in the 18" wide frying area
- Unique shape of tubes allows access to cold zone for easy cleaning
- Burner tubes are equipped with special heat baffles for fast recovery and energy efficiency
- Dual shortening levels (70 - 100 lbs) for varying cooking capacities
- Recessed Lexan faced control panel protects controls from damage



A N E T S
GoldenFry™



NSF

ANETS

Anetsberger Brothers, Inc. ■ Foodservice Equipment That Turns Food Into Gold
180 North Anets Drive ■ Northbrook, Illinois 60062
1-800-837-2638 ■ Fax 847-272-1943 ■ www.anetsberger.com

Anets GoldenFry™ 18" Fryer

Model 18AA



SPECIFICATIONS

- Model 18AA, Fully automatic twin basket lifts with 5 or 15 minute timers
- Certification UL, NSF
- BTUH 150,000
- Gas Pressure NG 3.5" WC, LP 10" WC
- Gas Connection 3/4" NPT
- Electrical Requirements 120 Volts, 5 Amps
- Thermostat Electric snap action type
- Temperature Range 200° to 375°F, (93°-191°C)
- Burners Atmospheric pre-mix
- Hi-limit Safety control turns off main gas supply at 435°F (224°C)
- Safety Pilot 100% gas shut off valve
- Spark Ignitor Piezo electric
- Frypot Stainless steel
- Tubes Stainless steel
- Cabinet Door, stainless steel
Sides, painted
Backsplash, stainless steel
- Shortening Capacity 70 lbs - 100 lbs
- Cooking Capacity 920 orders of shoestring french fries per hour

STANDARD ACCESSORIES

- 5 or 15 minute timers
- 2 Nickel plated twin baskets
- Rack type basket support
- Clean out rod
- 6" Adjustable chrome plated legs
- Drain pipe extension

OPTIONS AND ACCESSORIES

- Stainless steel sides
- Filter systems, built-in Filtronic or Filter Mate under fryer filter
- Fri-Tronic multi-product computer
- Solid state thermostat with shortening melter, boil out mode, and digital timers
- Can bank units at no additional charge
- Drain table
- Fryer cover
- Front drain tray
- Casters

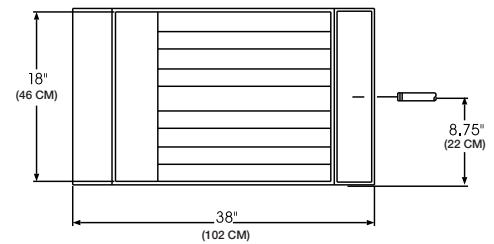

Top View

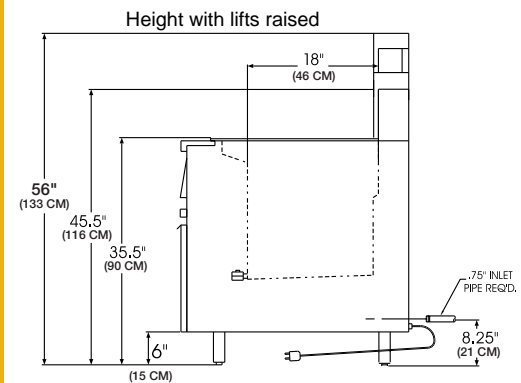

Side View

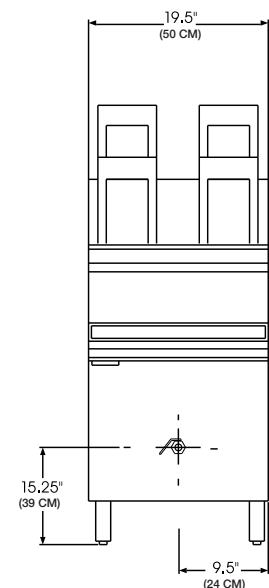

Front View

Specifications subject to change without notice.
SS#122 Revised 12/00
Printed in the U.S.A.



Anetsberger Brothers, Inc. ■ Foodservice Equipment That Turns Food Into Gold
180 North Anets Drive ■ Northbrook, Illinois 60062
1-800-837-2638 ■ Fax 847-272-1943 ■ www.anetsberger.com