

Item No.

Superior Performance With Exceptional Recovery For High Volume Electric Frying.

High efficiency 14KW ribbon-type immersion heaters provide efficient energy transfer for fast frying and quick recovery to increase cooking output of the fryer. Low watt density design prolongs the life of the elements and prevents scorching the shortening. Heaters swing up out of the way for ease of cleaning and access to the large cold zone.

STANDARD FEATURES

- Stainless steel frypot has a **lifetime warranty**.
- Stainless steel front panel, trim and door.
- Sealed construction immersion type 14KW heating elements made of a high temperature alloy with a stainless steel sheath.
- Heating elements lift up out of the way for easy cleaning of the frypot.
- Redundant contactors and hi-limit control for increased safety.
- Power, heating, and hi-limit lockout indicator lights are mounted conveniently on the front panel.
- Lexan faced control panel is recessed to protect controls from damage.
- Built-in circuit breaker and fuse holder mounted inside front door for easy access.
- Front 1-1/4" full port drain valve for easy no clog cleaning.
- Available with 2 heavy duty automatic basket lifts (14EL-14AA)
- Solid state thermostat for precise temperature control



Model 14EL - 14 shown with optional casters

A N E T S
GoldenFRY™



Anets 14" High Efficiency Electric Fryer

Model 14EL-14/14AA



SPECIFICATIONS

- Model
14EL-14, Electric Fryer
14EL-14AA, Electric fryer with automatic basket lifts
- Certification
NSF
- Electrical Requirements
Three phase, 14KW
208V-39A, 240V-34A
- Thermostat
Solid state
- Thermostat Range
200°-375°F (93°-190°C)
- Hi-Limit
Safety control shuts off power at 440°F (227°C)
- Frypot
Stainless steel welded construction
- Cabinet
Front panel, door, trim and backsplash are Stainless Steel.
Sides are painted
- Shortening Capacity
40-50 lbs.
- Cooking Capacity
70 lbs. french fries per hour
- Frying Area
14 x 14.5 in (36 x 37cm)

STANDARD ACCESSORIES

- Solid state thermostat
- 2 Nickel plated twin baskets
- 6" Adjustable legs
- Drain pipe extension
- Rack type basket support
- Clean out rod

OPTIONS AND ACCESSORIES

- Fri-Tronic™ multi-product computers with shortening melter, boil out mode and digital timers
- Filter Systems, built-in Filtronic or Filter Mate under fryer filter
- Automatic twin basket lifts (14EL-14AA)
- Stainless steel sides
- Casters
- Multiple units can be banked at no additional charge
- Single or triple baskets
- Drain table
- Front drain tray
- Cover
- Fryer cleaning brush

Specifications subject to change without notice.
SS# 142 1/09
Printed in the U.S.A.

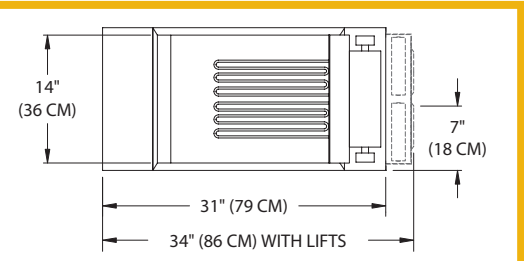

Top View

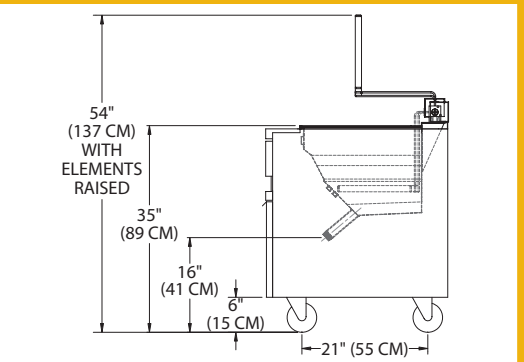

Side View

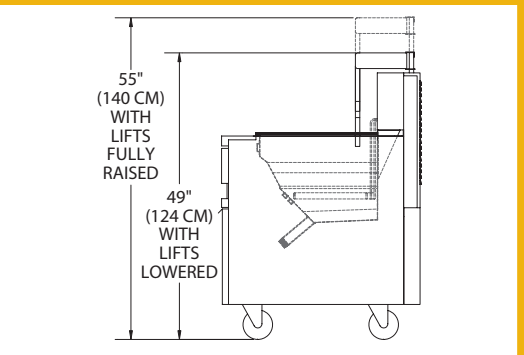

Side View With Lifts

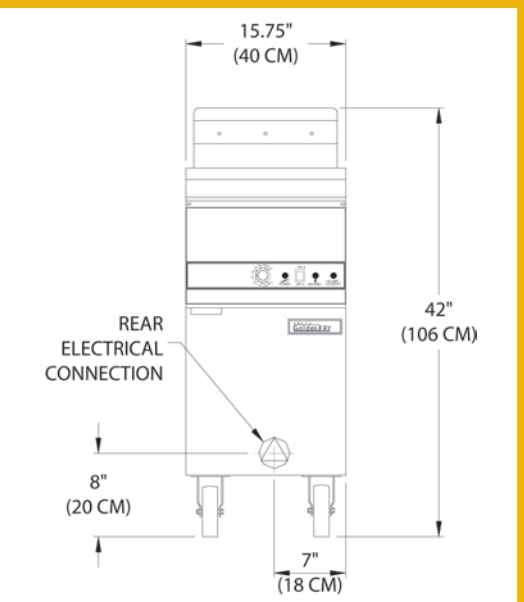

Front View



Anetsberger Brothers, Inc. ■ Quality is just the beginning
180 North Anets Drive ■ Northbrook, Illinois 60062-5452
1-800-837-2638 ■ Fax 847-272-1943 ■ www.anets.us