

Item No.

The Anets Filtronic™ Filter System Keeps Your Frying Operations At Peak Performance

Save on shortening and produce top quality product by filtering your shortening with the Filtronic II™ filter system. Simple to operate, this hands off system makes it easy to filter fast and filter often. Color coded handles are easy to identify. Filter one fryer while cooking in the others. Self contained system does not interfere with kitchen operations.

STANDARD FEATURES

- Available in 2 capacities 80 lb for 14" fryers, or 120 lb for any combination up to and including 20" fryers
- Can bank up to 6 fryers on one system
- New Anets filter element eliminates clogging when used with special filter paper envelopes
- Easy quick disconnect assembly
- Safety interlock shuts off burners to prevent empty frypot from heating
- Stainless steel filter tank is removable for easy cleaning
- All pipes and connections are heat shielded for operator safety
- Can be used as a portable filter (with optional hose assembly)
- Convert filter cabinet into holding station with the optional swivel heat lamp (Crispy Food Warmer)



Filt II - 14W shown
(model includes Crispy Food Warmer)
banked with
(2) MX - 14E fryers on optional casters



A N E T S
GoldenFRY™





SPECIFICATIONS

- **Model**
 Filt II-14, 14" built in filter system
 Filt II-14W, 14" built in filter system/
 with Crispy Food Warmer
 Filt II-18, 18" built in filter system
 Filt II-18W, 18" built in filter system/
 with Crispy Food Warmer
- **Certification**
 UL, NSF
- **Electrical Requirements - Filter Unit**
 120V, 1Ph, 60 HZ, 8 Amps
- **Electrical Requirements - Crispy Food Warmer**
 120V, 1Ph, 60 HZ, 4 Amps
- **Motor**
 1/3 HP
- **Pump Speed**
 5 Gallons per minute
- **Shortening Capacity**
 80 lb (14" model)
 120 lb (18-20" model)
- **Casters**
 2"
- **Cabinet**
 Door and front panel, stainless steel
 Sides, painted
 Backsplash, stainless steel
- **Filter Tank**
 Stainless steel

See individual fryer specification sheets for fryer specifications and options

STANDARD ACCESSORIES

- 100 Filter paper envelopes

OPTIONS AND ACCESSORIES

- Hose assembly for shortening disposal and converting filter to portable unit
- Cleaning brush
- Filter Power/Oil Purifier
- Envelope filter paper

Filtronic	A	B
14/14W	31"	15.63"
	79 CM	39 CM
18/18W	35"	19.63"
	89 CM	50 CM

Note: When ordering, specify filter cabinet location.

Specifications subject to change without notice.
 SS#224 Revised 12/03
 Printed in the U.S.A.

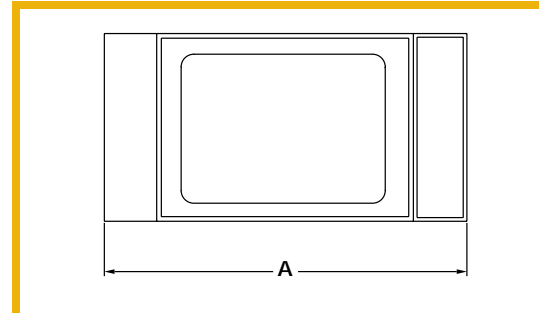

Top View

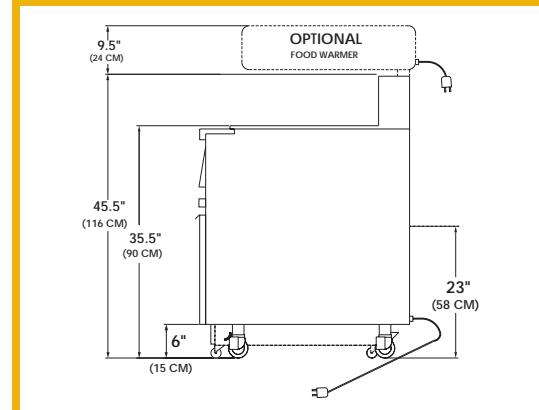

Side View

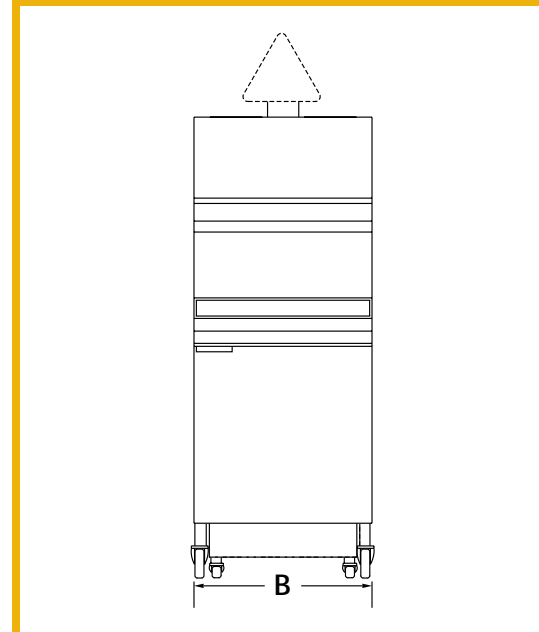

Front View